

Schutzhaube 47x53mm

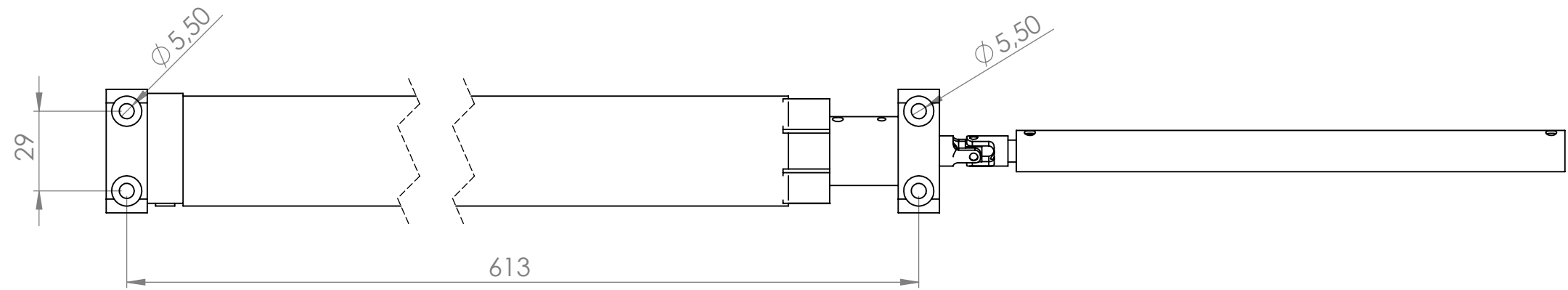
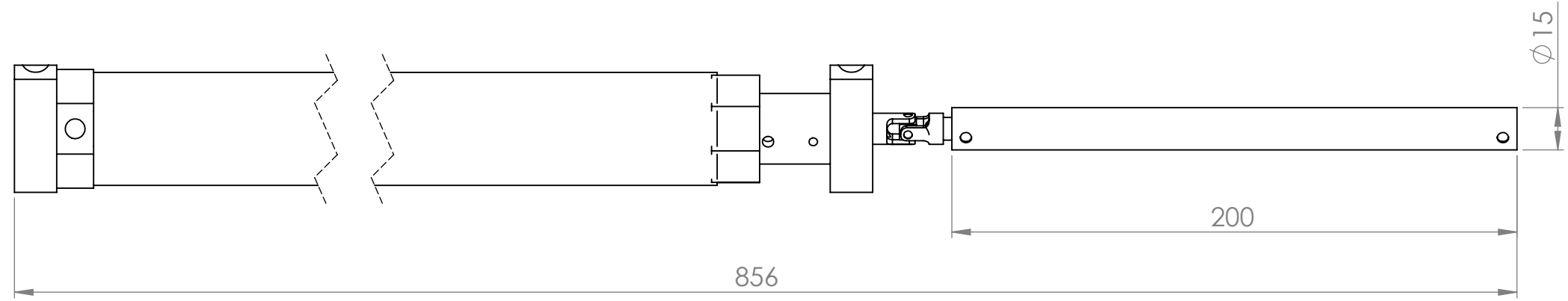
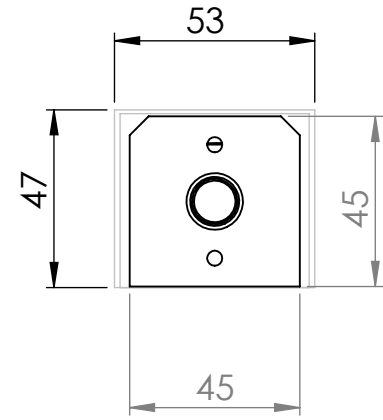

|   |  |  |  |               |  |                                   |  |                      |  |                                 |  |
|---|--|--|--|---------------|--|-----------------------------------|--|----------------------|--|---------------------------------|--|
| UNLESS OTHERWISE SPECIFIED:<br>DIMENSIONS ARE IN MILLIMETERS<br>SURFACE FINISH:<br>TOLERANCES:<br>LINEAR:<br>ANGULAR: |  |  |  | FINISH:       |  | DEBUR AND<br>BREAK SHARP<br>EDGES |  | DO NOT SCALE DRAWING |  | REVISION                        |  |
| DRAWN   |  |  |  | NAME          |  | SIGNATURE                         |  | DATE                 |  | TITLE:                          |  |
| CHK'D   |  |  |  | A. Schecklein |  |                                   |  | 22.05.2020           |  | NMK-1-10-V2.0                   |  |
| APPV'D  |  |  |  |               |  |                                   |  |                      |  |                                 |  |
| MFG   |  |  |  |               |  |                                   |  |                      |  |                                 |  |
| Q.A   |  |  |  |               |  |                                   |  |                      |  |                                 |  |
|   |  |  |  |               |  |                                   |  | MATERIAL:            |  | DWG NO.                         |  |
|   |  |  |  |               |  |                                   |  |                      |  | Baugruppe-1<br>ohne Schutzhaube |  |
|   |  |  |  |               |  |                                   |  | WEIGHT:              |  | SCALE:1:10                      |  |
|   |  |  |  |               |  |                                   |  |                      |  | SHEET 1 OF 1                    |  |
|   |  |  |  |               |  |                                   |  |                      |  | A3                              |  |